

Mailroom Operations

Streamlined, Secure Image Processing

While processing and storing paper is the traditional way for government agencies to meet record-keeping obligations, paper is a costly and inconvenient way to store information. Paper can also be misplaced, damaged or lost in a disaster. Many agencies have turned to image repositories to meet long-term storage needs. For agencies that receive information and payments through the mail, further efficiencies can be gained by turning paper into images at the earliest possible point: in the mailroom.



By converting incoming mail into images upon receipt, government agencies can minimize human error, increase flexibility, protect confidential information, and eliminate costs. ACS processes millions of mailroom documents each day to help agencies meet efficiency and security goals.

GETTING THE MOST OUT OF YOUR MAILROOM

While government mailrooms have gained some efficiencies using high-speed mail-opening equipment, many still give envelope contents to a data entry operator afterward. Human error is inevitable. By intelligently automating the capture of form data, ACS increases accuracy while lowering costs.

ACS' Master Control Program (MCP) provides an audit trail and monitors document progress in real time. Stages include:

- **Input:** Documents are scanned upon receipt and barcoded for tracking. Beyond mailroom input, ACS can also accept electronic data from web forms or faxes, or can convert stored document backlog to images on- or off-site.
- **Image and Data Capture:** ACS scans each document in a client-specified format, inspecting each image for quality. The system recognizes document types and captures data from the right fields.
- **Workflow Queues:** Imaged documents are routed for processing and validation based on document type, account status, and other data.
- **Post Processing:** ACS samples images for quality control to ensure that image quality and indexing accuracy meet acceptable standards.
- **Storage and Destruction:** Clients opt for ACS' hosted repository with no per-seat license fees or a system installed on the client's server. Originals are stored securely or destroyed upon client approval.
- **Retrieval:** Stored images are easily retrieved by authorized users with a secure web-based browser.

ACS' QUALIFICATIONS

- Processing seven million mailroom documents per day
- Creating 10 million images per day
- Processing up to 340 distinct document types per client
- Solid track record with federal and state client agencies as well as high-volume commercial clients

FEDERAL EXPERIENCE

- Experience hiring, training and retaining security-cleared personnel to process sensitive and confidential documents
- More than 80 million documents processed each year for federal agencies
- Social Security Administration
- Department of Homeland Security
- Department of Labor
- Department of Education

expertise in action™



RELATED SERVICES

- Front-end mailroom
- Image capture
- Data capture
- Post processing
- Storage

ACS Government Solutions
 1800 M Street, NW
 Washington, D.C. 20036
 202.378.2749
 email: acsfederal@acs-inc.com

www.acs-inc.com

This solution goes far beyond turning paper into images. It provides secure and convenient access to records wherever and whenever needed, with maximum accuracy, auditability, and accountability.

DESIGNED WITH GOVERNMENT IN MIND

ACS' solution is designed by former government managers who understand agency needs, constraints, and workflow. Benefits include:

- **Enhanced security:** Access control ensures that only those who have a need to access or modify records can do so, maintaining file integrity.
- **Better use of physical space:** Secure off-site storage or document disposal allows agencies to reclaim space previously used for filing.
- **Better service for stakeholders:** Multiple users can access information simultaneously from any internet-enabled browser.
- **Peace of mind when disaster strikes:** Backing up images to multiple locations provides uninterrupted availability – no matter what.

Mailroom Operations Workflow: Input to Output

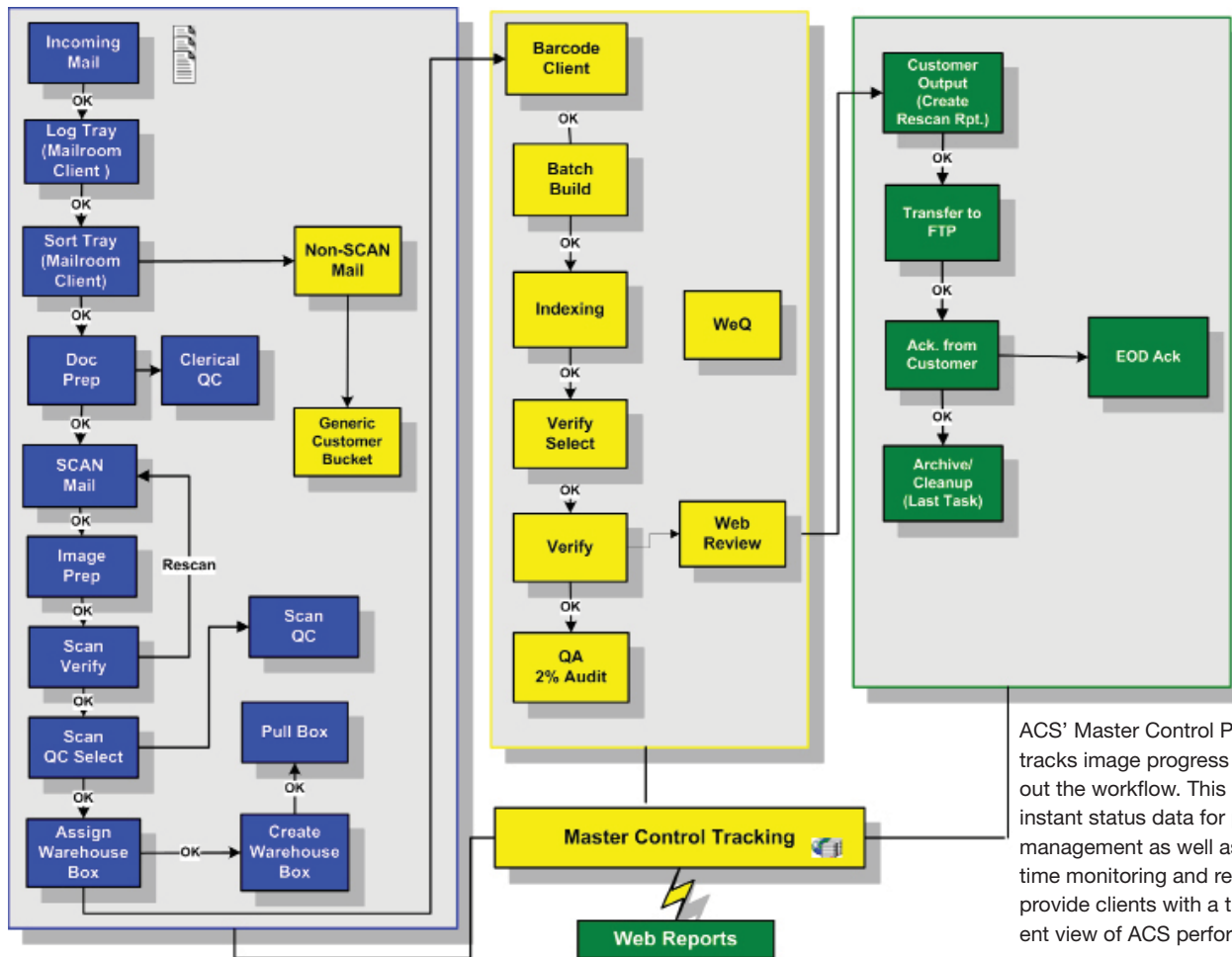

ACS' Master Control Process tracks image progress throughout the workflow. This delivers instant status data for project management as well as real-time monitoring and reports to provide clients with a transparent view of ACS performance.